

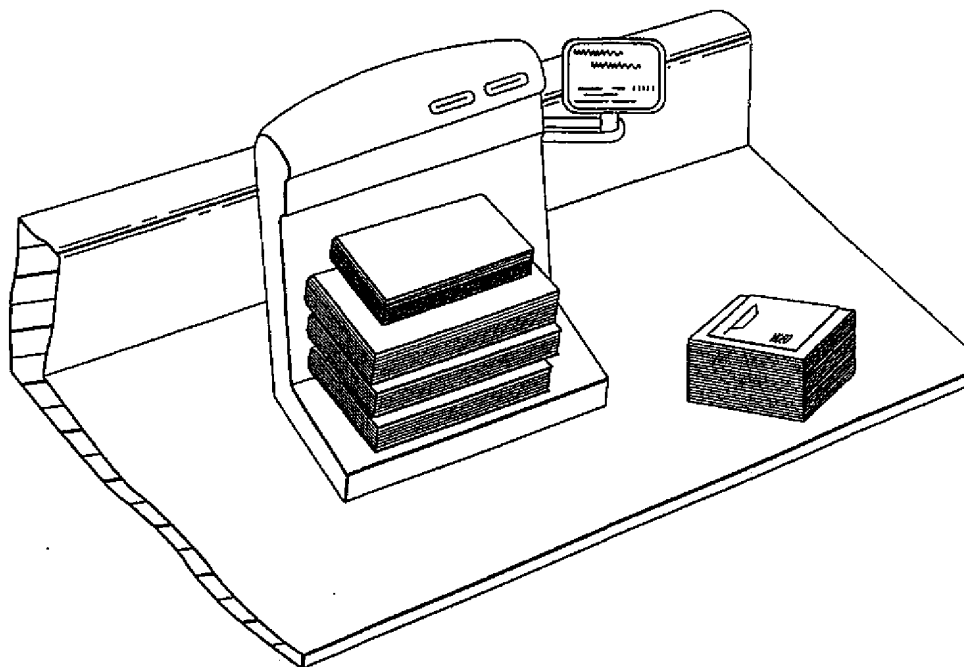

INTERNATIONAL APPLICATION PUBLISHED UNDER THE PATENT COOPERATION TREATY (PCT)

<p>(51) International Patent Classification ⁷ : G08B 13/24, G07F 7/00, G06F 17/60</p>	AI	<p>(11) International Publication Number: WO 00/10144</p> <p>(43) International Publication Date: 24 February 2000 (24.02.00)</p>
<p>(21) International Application Number: PCT/US99/17767</p> <p>(22) International Filing Date: 5 August 1999 (05.08.99)</p> <p>(30) Priority Data: 09/134686 14 August 1998 (14.08.98) US 09/344758 25 June 1999 (25.06.99) US</p> <p>(71) Applicant: 3M INNOVATIVE PROPERTIES COMPANY [US/US]; 3M Center, P.O. Box 33427, Saint Paul, MN 55133-3427 (US).</p> <p>(72) Inventors: GARBER, Sharon, R.; P.O. Box 33427, Saint Paul, MN 55133-3427 (US). GONZALEZ, Bernard, A.; P.O. Box 33427, Saint Paul, MN 55133-3427 (US). GRUNES, Mitchell, B.; P.O. Box 33427, Saint Paul, MN 55133-3427 (US). JACKSON, Richard, H.; P.O. Box 33427, Saint Paul, MN 55133-3427 (US). KAREL, Gerald, L.; P.O. Box 33427, Saint Paul, MN 55133-3427 (US). KRUSE, John, M.; P.O. Box 33427, Saint Paul, MN 55133-3427 (US). LINDAHL, Richard, W.; P.O. Box 33427, Saint Paul, MN 55133-3427 (US). NASH, James, E.; P.O. Box 33427, Saint Paul, MN 55133-3427 (US). PIOTROWSKI, Chester; P.O. Box 33427, Saint Paul, MN 55133-3427 (US). YORKOVICH, John, D.; P.O. Box 33427, Saint Paul, MN 55133-3427 (US).</p>	<p>(74) Agents: OLSON, Peter, L. et al.; 3M Innovative Properties Company, Office of Intellectual Property Counsel, P.O. Box 33427, Saint Paul, MN 55133-3427 (US).</p> <p>(81) Designated States: AE, AL, AM, AT, AU, AZ, BA, BB, BG, BR, BY, CA, CH, CN, CU, CZ, DE, DK, EE, ES, FI, GB, GD, GE, GH, GM, HR, HU, ID, IL, IN, IS, JP, KE, KG, KP, KR, KZ, LC, LK, LR, LS, LT, LU, LV, MD, MG, MK, MN, MW, MX, NO, NZ, PL, PT, RO, RU, SD, SE, SG, SI, SK, SL, TJ, TM, TR, TT, UA, UG, UZ, VN, YU, ZA, ZW, ARIPO patent (GH, GM, KE, LS, MW, SD, SL, SZ, UG, ZW), Eurasian patent (AM, AZ, BY, KG, KZ, MD, RU, TJ, TM), European patent (AT, BE, CH, CY, DE, DK, ES, FI, FR, GB, GR, IE, IT, LU, MC, NL, PT, SE), OAPI patent (BF, BJ, CF, CG, CI, CM, GA, GN, GW, ML, MR, NE, SN, TD, TG).</p> <p>Published <i>With international search report. Before the expiration of the time limit for amending the claims and to be republished in the event of the receipt of amendments.</i></p>	

(54) Title: APPLICATIONS FOR RADIO FREQUENCY IDENTIFICATION SYSTEMS



(57) Abstract

The present invention relates to RFID devices, including handheld RFID devices, and applications for such devices. The devices and applications may be used in connection with items that are associated with an RFID tag, and optionally a magnetic security element. The devices and applications are described with particular reference to library materials such as books, periodicals, and magnetic and optical media.

FOR THE PURPOSES OF INFORMATION ONLY

Codes used to identify States party to the PCT on the front pages of pamphlets publishing international applications under the PCT.

AL	Albania	ES	Spain	LS	Lesotho	SI	Slovenia
AM	Armenia	FI	Finland	LT	Lithuania	SK	Slovakia
AT	Austria	FR	France	LU	Luxembourg	SN	Senegal
AU	Australia	GA	Gabon	LV	Latvia	SZ	Swaziland
AZ	Azerbaijan	GB	United Kingdom	MC	Monaco	TD	Chad
BA	Bosnia and Herzegovina	GE	Georgia	MD	Republic of Moldova	TG	Togo
BB	Barbados	GH	Ghana	MG	Madagascar	TJ	Tajikistan
BE	Belgium	GN	Guinea	MK	The former Yugoslav Republic of Macedonia	TM	Turkmenistan
BF	Burkina Faso	GR	Greece			TR	Turkey
BG	Bulgaria	HU	Hungary	ML	Mali	TT	Trinidad and Tobago
BJ	Benin	IE	Ireland	MN	Mongolia	UA	Ukraine
BR	Brazil	IL	Israel	MR	Mauritania	UG	Uganda
BY	Belarus	IS	Iceland	MW	Malawi	US	United States of America
CA	Canada	IT	Italy	MX	Mexico	UZ	Uzbekistan
CF	Central African Republic	JP	Japan	NE	Niger	VN	Viet Nam
CG	Congo	KE	Kenya	NL	Netherlands	YU	Yugoslavia
CH	Switzerland	KG	Kyrgyzstan	NO	Norway	ZW	Zimbabwe
CI	Côte d'Ivoire	KP	Democratic People's Republic of Korea	NZ	New Zealand		
CM	Cameroon			PL	Poland		
CN	China	KR	Republic of Korea	PT	Portugal		
CU	Cuba	KZ	Kazakstan	RO	Romania		
CZ	Czech Republic	LC	Saint Lucia	RU	Russian Federation		
DE	Germany	LI	Liechtenstein	SD	Sudan		
DK	Denmark	LK	Sri Lanka	SE	Sweden		
EE	Estonia	LR	Liberia	SG	Singapore		

APPLICATIONS FOR RADIO FREQUENCY IDENTIFICATION SYSTEMS

INCORPORATION BY REFERENCE

5 This patent application claims priority from U.S. application serial number
09/134,686, filed August 14, 1998 with the same title, and U.S. application serial
number 09/344,758, filed June 25, 1999 with the same title, both of which were assigned
to the assignee of the present invention, and the contents of both of which are
incorporated by reference herein.

10

TECHNICAL FIELD

The invention relates to applications for radio frequency identification (RFID)
systems, and particularly to the use of such systems in libraries.

15

BACKGROUND OF THE INVENTION

Electronic article surveillance ("EAS") systems detect the presence of small
electronic devices placed on or in an article or carried by a person of interest, and are
often used in retail or library environments to deter theft or other unauthorized removal
of articles. These devices, which are commonly known as tags or markers, have in the
20 past contained only information regarding the presence of an item. This information
could be obtained by electronically interrogating the tag, either intermittently or
continuously. At least four distinct types of EAS systems have evolved over the years,
based on how this interrogation was carried out: magnetic, magnetomechanical, radio
frequency (RF), and microwave. Of these four, magnetic systems have provided the
25 highest level of security in most applications. Magnetic tags are easily hidden in or on
an object, difficult to detect (because they are less susceptible to shielding, bending, and
pressure), and easy to deactivate and reactivate, thereby providing a high degree of
security and some information regarding the status of the tagged article.

30

Many users of EAS systems desire to know more than just whether a tagged
object is present. They also want to know which tagged object is present, for example.
Detailed information regarding the characteristics of objects, such as their date of
manufacture, inventory status, and owner have generally been communicated to

automated handling and control systems through an optical bar code. While inexpensive and effective, the optical bar code system has certain limitations. Bar codes must be visible, which limits the locations in which they may be placed, and bar codes can easily be obscured, either accidentally or intentionally. The range at which a detector can sense the bar code is also comparatively small. The bar code may also have to be appropriately positioned for detection. Also, because bar codes are often exposed to permit detection, the barcode is susceptible to damage that can result in detection failures. Lastly, multiple items must be processed one at a time. These constraints of bar code systems make them undesirable or inefficient for some applications, such as marking library media.

More recently, electronic identification (also known as radio frequency identification or RFID) techniques have been developed to address the limitations of optical barcodes. RFID systems have succeeded in providing object identification and tracking, but are deficient in providing object security because most RFID systems operate in frequency ranges (~1 MHz and above) in which the tag is easily defeated. The security deficiency associated with radio frequency tags arises because they can be "shielded" by, for example, covering the tag with a hand or aluminum foil, or even placing the tag in a book. Even battery-powered radio frequency tags may be blocked, although their range is superior and blocking would be more difficult. Thus, objects tagged with an RFID tag may escape detection, either inadvertently or intentionally. This greatly reduces their effectiveness as security devices. RFID markers are also related to "smart cards." Both contact and contactless smart cards have appeared in commercial applications. Smart cards tend to be associated with a specific person rather than with a tagged object. Issues related to the security and tracking of the smart card (or of the person carrying it) are similar to those discussed above for RFID markers.

The security issues associated with RFID markers are similar to those familiar to anyone skilled in the art of radio frequency- and microwave-based EAS tags. Substantial effort has been expended in attempts to remedy the deficiencies of radio frequency- and microwave-based EAS tags. However, none has substantially improved their performance as security tags. U.S. Patent No. 5,517,195 (Narlow et al.), entitled "Dual Frequency EAS Tag with Deactivation Coil," describes a dual frequency

microwave EAS tag that includes an antenna circuit having a diode, and a deactivation circuit. The deactivation circuit responds to a low energy alternating magnetic field by inducing a voltage in the diode of the antenna circuit so as to disable the diode and the antenna, thereby deactivating the tag. Although useful for some applications, the
5 capacitor-based tag disclosed in Narlow et al. may leak electrical charge over time, which could cause the tag to become activated unintentionally.

Radio frequency EAS tags of the type disclosed in U.S. Patent No. 4,745,401 (Montean et al.) include a magnetic element. The magnetic element alters the tuning of
10 the tag when it has been suitably magnetized by an accessory device, and thereby blocks the radio frequency response of the tag. Although these tags have a certain utility, they still do not address the issues of enhanced security and identification.

Radio frequency identification technology has been developed by a number of
15 companies, including Motorola/Indala (see U.S. Patent Numbers 5,378,880 and 5,565,846), Texas Instruments (see U.S. Patent Numbers 5,347,280 and 5,541,604), Mikron/Philips Semiconductors, Single Chip Systems (see U.S. Patent Numbers 4,442,507; 4,796,074; 5,095,362; 5,296,722; and 5,407,851), CSIR (see European document numbers 0 494 114 A2; 0 585 132 A1; 0 598 624 A1; and 0 615 285 A2),
20 IBM (see U.S. Patent Numbers 5,528,222; 5,550,547; 5,521,601; and 5,682,143), and Sensormatic Electronics (see U.S. Patent No. 5,625,341). These tags all attempt to provide remote identification without the need for a battery. They operate at frequencies ranging from 125 KHz to 2.45 GHz. The lower frequency tags (~125 KHz) are moderately resistant to shielding, but have only limited radio frequency
25 functionality due to bandwidth constraints. In particular, systems based on these markers generally operate reliably only when a single tag is in the interrogation zone at a time. They also tend to be relatively bulky and expensive to manufacture. At higher frequencies, (typically 13.56 MHz, 915 MHz, and 2.45 GHz), the added bandwidth available has permitted the development of systems which can reliably process multiple
30 tags in the interrogation zone in a short period of time. This is highly desirable for many product applications. In addition, some of the tag designs hold the promise of being relatively inexpensive to manufacture and therefore more attractive to a customer. However, these higher frequency devices share to varying degrees the susceptibility to

shielding discussed earlier. Thus, they cannot provide the high level of security demanded in certain applications, such as a library

5 From the foregoing discussion, it should be clear that there are a number of applications for RFID tags in various environments in which the identity of the tagged item is important. For example, PCT Publication WO 99/05660, published February 4, 1999 and assigned to Checkpoint Systems, Inc., describes an inventory system using articles with RFID tags. The preferred embodiment described therein contemplates the use of RFID tags in library materials, which may then be checked out automatically by
10 interrogating the RFID tag to determine the identify of the material. However, a number of important or desirable library or other inventory functions remain that are not described or suggested in the '660 publication.

SUMMARY OF THE INVENTION

15 The present invention relates to RFID devices, including handheld RFID devices, and applications for such devices. The devices and applications may be used in connection with items that are associated with an RFID tag, and optionally a magnetic security element. The devices and applications are described with particular reference to library materials such as books, periodicals, and magnetic and optical media. Other
20 applications for the present invention are also envisioned.

BRIEF DESCRIPTION OF THE DRAWINGS

The present invention is described in greater detail with reference to the attached Figures, in which like numbers represent like structure throughout the several views, and
25 in which

Figures 1A and 1B are schematic illustrations of radio frequency identification tags;

Figure 2 is a schematic of a second embodiment of a radio frequency identification tag;

30 Figure 3 is a schematic top view of a combination tag;

Figure 4 is a block diagram of an RFID interrogation system interacting with an RFID tag;

Figures 5, 6, 7, and 8 are illustrations of combination tags according to the present invention; and

Figures 9, 10, 11, 12, 13, and 14 are illustrations of various embodiments of the present invention.

5

DETAILED DESCRIPTION OF THE INVENTION

The embodiments of the present invention described herein make use of RFID tags, and preferably of combination RFID/magnetic security tags. Tags of this type were disclosed in U.S. Application Serial Number 09/093,120, filed June 8, 1998 and entitled "Identification Tag With Enhanced Security," which was assigned to the assignee of the present invention and was incorporated by reference into the U.S. application from which the present application claims priority. A detailed description of the magnetic, RFID, and combination tags used in conjunction with the embodiments of the present invention is described in Section I, below, and the embodiments of the present invention are then set forth in detail in Section II, below.

10

15

I. Tags and Elements For Use With Embodiments of the Present Invention

A tag used with the embodiments of the invention described in Section II, below, may incorporate both object identification and effective security in a single device. They preferably include an element that is responsive to a magnetic interrogation signal, and an element that is responsive to a radio frequency interrogation signal. In one embodiment, the magnetically-responsive element also provides the antenna for the radio frequency-responsive element. The term "responsive" means, in the context of the present invention, that the element provides intelligible information when subjected to an appropriate interrogation field. The individual elements are described first below, followed by a description of a combination tag. As will become apparent, the embodiments of the present invention described in Section II, below, may include either an RFID element alone, or a combination of an RFID element and a magnetic security element.

20

25

30

A. The Magnetically-Responsive Element

The magnetically-responsive element is preferably made of a low coercive force, high permeability ferromagnetic material, such as the material used in the strips sold by

the Minnesota Mining and Manufacturing Company of St. Paul, Minnesota (3M) under the designation "TATTLE-TAPE™" brand strips. These strips, or marker assemblies, are described in several patents assigned to 3M, including U.S. Patent Nos. 5,331,313 (Koning) and 3,747,086 (Peterson), the contents of which are incorporated by reference
5 herein. Exemplary low coercive force, high permeability ferromagnetic materials include permalloy (a nickel/iron alloy), and high performance amorphous metals such as those available from the AlliedSignal Company of Morristown, NY under the designations Metglas 2705M and Metglas 2714A.

10 The magnetically-responsive element may be either single status or dual status, depending on the nature of the article with which the element is associated. For example, certain reference books in libraries are not to be removed from the library, and thus a single-status (non-deactivatable) marker would always indicate whether such a
15 book passed within an interrogation zone. Other articles, such as common library materials or commercial goods, may require a dual-status marker assembly, so that when the article has been properly processed the marker may be appropriately deactivated to prevent detection by the interrogation source. Dual status functionality is generally provided through the addition of sections of higher coercivity magnetic material in
20 proximity to the low coercivity magnetic material, as described below and in the Peterson patent incorporated by reference above.

Certain magnetically-responsive elements have the ability to switch magnetic orientation rapidly when passed through a low frequency alternating magnetic field (50 Hz to 100 KHz, for example), and to produce a predetermined characteristic response
25 that may be detected by the receiving coils of a detector. The switching function of the marker assembly is controlled by the magnetization state of the high coercive force elements, or "keeper elements." When these keeper elements are magnetized, the ability of the marker to magnetically switch back and forth within the alternating magnetic field of the interrogation zone is altered, and the marker typically is not detected. When the
30 keeper elements are demagnetized, the marker can again perform the switching function, enabling the interrogation source to detect the presence of the marker. The keeper elements may be provided in different ways, as is known in the art.

The marker assembly may also include adhesive on one or both sides thereof, to enable the marker to be bonded to a book or other article. The adhesive layer(s) may be covered by a removable liner, to prevent adhesion of the marker to an unintended surface prior to application to the intended surface. These and other features of the marker assembly are described in the U.S. Patent Nos. 3,790,945 (Fearon), 5,083,112 (Piotrowski), and 5,331,313 (Koning), all incorporated by reference above.

Because low frequency magnetic elements of this type are difficult to shield from detection, they may be effectively used on a wide variety of items when security is important. In addition, they may be deactivated and reactivated more conveniently, completely, and repeatedly than markers employing other EAS technologies, making them more suitable for use in certain applications (such as libraries) where this characteristic is highly desirable.

B. The Radio Frequency-Responsive Element

RFID tags can be either active or passive. An active tag incorporates an additional energy source, such as a battery, into the tag construction. This energy source permits active RFID tags to create and transmit strong response signals even in regions where the interrogating radio frequency field is weak, and thus an active RFID tag can be detected at greater range. However, the relatively short lifetime of the battery limits the useful life of the tag. In addition, the battery adds to the size and cost of the tag. A passive tag derives the energy needed to power the tag from the interrogating radio frequency field, and uses that energy to transmit response codes by modulating the impedance the antenna presents to the interrogating field, thereby modulating the signal reflected back to the reader antenna. Thus, their range is more limited. Because passive tags are preferred for many applications, the remainder of the discussion will be confined to this class of tag. Those skilled in the art, however, will recognize that these two types of tags share many features and that both can be used with this invention.

30

As shown in Figure 1, a passive radio frequency-responsive element 10 typically includes two components: an integrated circuit 12 and an antenna 14. The integrated circuit provides the primary identification function. It includes software and circuitry to

permanently store the tag identification and other desirable information, interpret and process commands received from the interrogation hardware, respond to requests for information by the interrogator, and assist the hardware in resolving conflicts resulting from multiple tags responding to interrogation simultaneously. Optionally, the integrated circuit may provide for updating the information stored in its memory (read/write) as opposed to just reading the information out (read only). Integrated circuits suitable for use in RFID markers include those available from Texas Instruments (in their TIRIS or Tag-it line of products), Philips (in their I-Code, Mifare and Hitag line of products), Motorola/Indala, and Single Chip Systems, among others.

The antenna geometry and properties depend on the desired operating frequency of the RFID portion of the tag. For example, 2.45 GHz (or similar) RFID tags would typically include a dipole antenna, such as the linear dipole antennas 4a shown in Figure 1A, or the folded dipole antennas 14a shown attached to the radio frequency responsive element 10a in Figure 1B. A 13.56 MHz (or similar) RFID tag would use a spiral or coil antenna 14b, as shown attached to the radio frequency responsive element 10b in Figure 2. In either case, the antenna 14 intercepts the radio frequency energy radiated by an interrogation source. This signal energy carries both power and commands to the tag. The antenna enables the RF-responsive element to absorb energy sufficient to power the IC chip and thereby provide the response to be detected. Thus, the characteristics of the antenna must be matched to the system in which it is incorporated. In the case of tags operating in the high MHz to GHz range, the most important characteristic is the antenna length. Typically, the effective length of a dipole antenna is selected so that it is close to a half wavelength or multiple half wavelength of the interrogation signal. In the case of tags operating in the low to mid MHz region (13.56 MHz, for example) where a half wavelength antenna is impractical due to size limitations, the important characteristics are antenna inductance and the number of turns on the antenna coil. For both antenna types, good electrical conductivity is required. Typically, metals such as copper or aluminum would be used, but other conductors, including magnetic metals such as permalloy, are also acceptable and are, in fact, preferred for purposes of this invention. It is also important that the input impedance of the selected IC chip match the impedance of the antenna for maximum energy transfer. Additional information about antennas is known to those of ordinary skill in the art

from, for example, reference texts such as J.D. Kraus, Antennas (2d ed. 1988, McGraw-Hill, Inc., New York).

A capacitor 16 is often included to increase the performance of the marker, as shown in Figure 2. The capacitor 16, when present, tunes the operating frequency of the tag to a particular value. This is desirable for obtaining maximum operating range and insuring compliance with regulatory requirements. The capacitor may either be a discrete component, or integrated into the antenna as described below. In some tag designs, particularly tags designed to operate at very high frequencies, such as 2.45 GHz, a tuning capacitor is not required. The capacitor is selected so that, when coupled to the inductance provided by the antenna, the resonant frequency of the composite structure, given by:

$$f_r = \left(\frac{1}{2\pi} \right) \sqrt{\frac{1}{LC}}$$

where

- 15 C = capacitance (in Farads)
 L = inductance (in Henries)

20 closely matches the desired operating frequency of the RFID system. The capacitor may also be a distributed capacitor as described in U.S. Patent Nos. 4,598,276 (Tait et al.) and 4,578,654 (Tait et al.), which are assigned to 3M. Distributed capacitance is desirable to reduce tag size, particularly thickness, and to minimize manual assembly.

25 In operation, as shown in Figure 4, the radio frequency-responsive tag 110 is interrogated by an EAS security system 100, which is typically located near the point at which the tags are to be monitored. An interrogation zone may be established by placing spaced detection panels across the exits from the room in which the tagged articles are located, near a conveyor carrying items to be monitored, or the like. Hand held detection devices may also be used. An interrogation source 102 (typically including a drive oscillator and an amplifier) is coupled to an antenna 104 (sometimes described as a field coil) for transmitting an alternating radio frequency field, or
30 interrogation signal, in the interrogation zone. The system 100 also includes an antenna

for receiving a signal (shown as antenna 104, and sometimes described as a receiving coil) and detector 106 for processing signals produced by tags in the interrogation zone.

5 The interrogation source 102 transmits an interrogation signal 200, which may be selected within certain known frequency bands that are preferred because they do not interfere with other applications, and because they comply with applicable government regulations. When the radio frequency-responsive element receives an interrogation signal it transmits its own response code signal 202 that is received by the antenna 104 and transmitted to detector 106. The detector decodes the response, identifies the tag
10 (typically based on information stored in a computer or other memory device 108), and takes action based on the code signal detected. Various modifications of the illustrated system are known to those of skill in the art including, for example, using separate antennas for the interrogation source 102 and the detector 106 in place of the single antenna 104 that is illustrated.

15

Modern RFID tags also provide significant amounts of user accessible memory, sometimes in the form of read-only memory or write-once memory, but more preferably offering the user the ability to repeatedly update the memory by rewriting its contents from a distance. The amount of memory provided can vary, and influences the size and cost of the integrated circuit portion of an RFID tag. Typically, between 128 bits and
20 512 bits of total memory can be provided economically. For example an RFID tag available from Texas Instruments of Dallas, Texas, under the designation "Tag-it" provides 256 bits of user programmable memory in addition to 128 bits of memory reserved for items such as the unique tag serial number, version and manufacturing information, and the like. Similarly, an RFID tag available from Philips Semiconductors
25 of Eindhoven, Netherlands, under the designation "I-Code" provides 384 bits of user memory along with an additional 128 bits reserved for the aforementioned types of information.

30

This user accessible memory may be exploited to enhance the performance of an item identification system deployed, for example, in a library environment. Presently, libraries identify items by scanning an optical barcode. The unique identifier contained in this barcode is used to access a circulation database including software provided by

library automation vendors (LAV software), where more extensive information about the item is permanently maintained. While this system has been highly developed and works very well in many applications, it may have two disadvantages. First, a connection to the circulation database must be established to access the information.

5 This limits the availability of the information when an item is at a location remote from a connection to this database. Second, the retrieval of information from the circulation database can sometimes require an unacceptably long time, particularly during periods of heavy use. By storing certain critical items of information on the RFID tag, both of these limitations can be overcome.

10

One example of information which could improve the performance of a library identification system if present on the RFID tag itself would be a library identification number. Then, without accessing a database, an item's "home" library could be quickly and conveniently determined by simply scanning the RFID label. Another example of information preferably present on an RFID tag itself would be a code designating whether the item was a book, a video tape, an audio tape, a CD, or some other item. This code could, for example, comprise the media type code specified in the 3M Standard Interchange Protocol, which is available from the assignee of the present invention. By immediately knowing the media type, a library's material management systems could insure that an item was being appropriately processed without incurring the delay and inconvenience of consulting a remote circulation database. Other examples of information suitable for incorporation into the RFID label will be apparent to those skilled in the art.

15

20

25

Another area in which RFID systems offer an advantage over barcode-based systems is in the identification of multiple items. By using sophisticated software algorithms, RFID readers and markers cooperate to insure that all items in the reader's interrogation zone are successfully identified without intervention by the operator. This capability enables the development of numerous useful applications in the areas of inventory control, item tracking, and sorting that would be difficult or impossible to implement with barcode-based identification systems.

30

C. The Combination Tag

As shown in Figures 3 and 5 through 8, the combination tag 20 combines a magnetically-responsive element with an RF-responsive element to provide the advantages of both. Thus, the two elements can be applied to an item of interest at the same time, thereby reducing cost. The combination tag may be provided with a pressure sensitive adhesive covered by a removable liner, which enables the combination tag to be adhered to a surface of the article when the liner has been removed. In another embodiment, the tag uses the magnetically-responsive element as an antenna for the radio frequency-responsive element. The magnetically-responsive element, when used as an antenna, is electrically coupled to the radio frequency-responsive element, and may or may not also be physically coupled to the radio frequency-responsive element.

The combination tag made according to the present invention may be interrogated two ways. First, the RFID interrogation source would use radio frequency signals to request and receive codes from the integrated circuit. This information would indicate, for example, the identification of the article with which the tag is associated, and whether the article had been properly processed. Second, a magnetic interrogation field would interrogate the tag to determine whether the magnetic portion of the marker assembly was active. If the marker assembly was active, the interrogation source would produce a response, such as a notification that the marked article had not been properly processed. Because the magnetic interrogation is more resistant to shielding than the radio frequency interrogation, the magnetic portion of the combination tag would provide enhanced security. Thus, the features of both magnetic and RFID tags are combined into a single combination tag.

In a preferred embodiment, the combination tag includes a magnetically-responsive element that also functions as the antenna in the circuitry of the radio frequency-responsive element. To serve both functions, the antenna material must exhibit low magnetic coercivity and very high magnetic permeability (to serve as an efficient security element), and moderate to high electrical conductivity (to function as an efficient antenna). In addition, the geometry of the antenna must be compatible with both functions. In this embodiment, the antenna could, for example, be fabricated from permalloy, an alloy of nickel and iron.

In one embodiment, a 3M "Tattle-Tape™" brand security strip, or other equivalent magnetic element, may be used as a linear dipole antenna to operate at 2.45 GHz or a similar high frequency. The length, width and thickness of this strip are selected to match the particular operating frequency and other characteristics of the RFID chip used. Typically, the strip would be made from permalloy (available from a number of sources including Carpenter Specialty Alloys, Reading, PA, under the trade name "HyMu80") or an amorphous alloy such as that available from the AlliedSignal Company of Morristown, NY, under the designation 2705M, and its length would be between 6.35 and 16.5 cm (2.5 and 6.5 inches). The terminals of the integrated circuit would be physically connected to the ends of the security strip. Electrical measurements of impedance and power gain have established that such a magnetic strip provides the same fundamental electrical characteristics as the copper or aluminum dipole antennas normally used with such a chip, and thus it would be expected to perform both functions satisfactorily.

When the magnetically-responsive element is used as at least part of the antenna for the radio frequency-responsive element, the two are electrically coupled to each other. Electrical coupling may occur because of a physical connection between multiple elements (as shown in Figure 5), or, in the absence of a physical connection, by non-contact electromagnetic coupling (as shown in Figures 6, 7, and 8). Non-contact coupling can include parasitic coupling, capacitive coupling, or inductive coupling, and use such antenna components as parasitic antenna elements, reflector and director antennas, Yagi-Uda antennas, or other suitable antenna configurations.

The combination tag shown in Figure 3 includes coil turns made from magnetic material. The tag could be, for example, a 13.56 MHz tag having an antenna structure such as 14c in which flux collectors are provided at the corners to improve the magnetic function of the tag. Other types of flux collectors may be provided.

The combination tag 20 shown in Figure 5 includes a physical connection between the antenna 22, which is made of magnetically-responsive material, and the integrated circuit 12. One or more keeper elements or the type described above also

may be applied to the magnetically-responsive material, so that it may be selectively activated and deactivated to provide a dual status tag. The antenna 22a shown in Figure 6, however, is not physically connected to the integrated circuit 12 or the dipole antenna 23, but is nonetheless electrically coupled to the dipole antenna by parasitic dipole coupling to provide a combination tag 20a. The dipole antenna 23 may comprise either magnetically-responsive material or non-magnetically-responsive material.

Figures 7 and 8 illustrate embodiments in which more than one antenna 22 is provided to electrically couple with antennas 23b and 23c, respectively. In the combination tag 20b shown in Figure 7, integrated circuit 12 includes dipole antenna 23b, which is parasitically coupled to antennas 22b. Antennas 22b are made of magnetically-responsive material, and antenna(s) 23b may be made of magnetically-responsive material. In the combination tag 20c shown in Figure 8, a radio frequency-responsive element of the type shown in Figure 2 is parasitically electrically coupled to antennas 22c. Antennas 22c are made of magnetically-responsive material, and antenna(s) 23c may be made of magnetically-responsive material. Other variations of these embodiments are easily designed.

The overall thickness of the combination tag should be as small as possible, to enable the tag to be inconspicuously placed on or in an article. For example, the tag may be applied with adhesive between the pages of a book, and it is desirable to make the tag thin enough to prevent easy detection by observing the end of the book. Conventional ICs may be approximately 0.5 mm (0.02 in) thick, and the overall thickness of the tag is preferably less than 0.635 mm (0.025 in).

The combination tags of this invention may be provided in roll form, to enable the automated sequential application of individual tags to articles. This general system is described in, for example, PCT Publication No. WO 97/36270 (DeVale et al.). Individual combination tags, one or more surfaces of which may be covered by an adhesive (such as a pressure sensitive adhesive), may be removed from the roll and applied between two pages of a book, near its binding. A page spreader may be provided to facilitate insertion of the combination tag, and other options such as sensors to detect the position of various components in the system may also be provided.

The combination tag is believed to have particular, although not exclusive, use in the processing of library materials. Library materials having an RFID tag of this type could be checked in and out more easily, perhaps without human assistance. That is, the materials would automatically be checked out to a particular patron (who may herself have an RFID tag associated with her library card) when the patron passes through a suitable detection zone, and checked back in when the patron re-enters the library with the materials. The tag of the invention may also assist in inventory management and analysis, by enabling library administrators to keep track of materials instantaneously and continuously. These and other features of the invention can, of course, be brought to bear on other applications, such as materials handling in stores, warehouses, and the like.

In another embodiment, the combination tag could provide dual-status marker information both through a magnetic response (indicating whether the magnetic features of the tag had been activated or deactivated) and through a radio frequency response (indicating, through the use of appropriate software, whether the database or the memory on the RFID chip itself showed that the item had been appropriately processed).

The following Examples provide still further information as to the tags used in the embodiments of the invention described in Section II, below.

Example One

A combination tag was made in accordance with the present invention. A permalloy strip produced from an alloy available from the Carpenter Technology Corporation of Reading, Pennsylvania under the designation "HyMu80" was attached to a test fixture manufactured by Single Chip Systems (SCS) of San Diego, California. The strip measured approximately 1.6 mm (0.625 in) wide by 0.0254 mm (0.001 in) thick by 10.16 cm (4 in) long. The test fixture consisted of a standard SCS 2.45 GHz antenna connected to an LED diode. The device was designed so that upon exposure to a 2.45 GHz field strong enough to power a typical SCS RFID tag the LED would glow, providing an immediate visible confirmation of the proper operation of the power-receiving portion of the device. Upon replacing the standard SCS antenna with the

prototype permalloy antenna, the LED illuminated at approximately the same field strength, confirming the successful operation of the prototype.

Example Two

5 Figure 3 illustrates another embodiment of an antenna that is believed useful with a 13.56 MHz RFID design. At this frequency, a coil-type antenna geometry is preferred. The spiral turns comprising the coil are formed from a magnetic alloy such as permalloy, either by etching (physical or chemical), die cutting, or deposition through a mask. The straight "arm" portions of the coil serve also as the magnetically responsive elements in
10 this design. However, the reduced length of these metallic elements in this geometry limits the effectiveness of the magnetic security portion of the device. In the embodiment shown in Figure 3, flux collection elements provided at the corners have been added to the antenna coil to overcome this limitation. The construction shown in Figure 3 would, preferably, include a capacitor as previously described to tune the
15 operating frequency of the antenna to the prescribed interrogation frequency.

The characteristics of the antenna described in this example were compared with the characteristics of known antennas for radio frequency integrated circuits, and because those characteristics were similar, it is believed that the antenna of this example
20 would function adequately in such an application.

The embodiments of the present invention described below may use either a tag having only an RFID element, or a combination tag, both of which are described above.

25 II. Embodiments of the Present Invention

A. RFID Device with Magnetic Capabilities.

Because RFID tags may be shielded either intentionally or unintentionally by a library patron, it is often important to provide both RFID and magnetic security
30 elements in the tagged library material, preferably on the same tag. When the magnetic security element is dual status, meaning that it may be selectively activated and deactivated, its status is typically changed by the application of a magnetic field to that element. Magnetization operations such as this have no effect on library materials such

as books and magazines, but can have harmful effects on magnetically-recorded media. The inventive RFID device with magnetic capabilities solves such problems, preferably without any involvement by library staff members.

5 As shown in Figure 9, an RFID device is equipped to read information from an RFID tag on an item, such as a patron card, book, or other material. Preferably, the information read from the RFID tag includes a designation of media type (magnetic, print, or optical, for example), which can be used to insure the proper subsequent processing of the item. The RFID device is also equipped with a device, such as the
10 coil, designed to enable the activation and deactivation of the security element portion of the item tag. After the RFID device reads the RFID tag, the device transmits the item identification information to a computer having software provided by a library automation vendor, or LAV. Among approximately 50 current LAV software systems are "Dynix," which is available from Ameritech Library Services of Provo, Utah, "Carl
15 ILS" which is available from CARL Corporation of Denver, Colorado, and "DRA," which is available from DRA, of St. Louis, Missouri.

 There are a number of ways to transmit the information obtained from an RFID tag to the LAV system. One would involve using the commands implemented in the 3M
20 Standard Interchange Protocol (SIP). Another would involve using an electronic device known as a "wedge" to transmit the information as if it originated from a conventional barcode scanner. These and other techniques are well-known to those skilled in the art. In this manner, the RFID component of the RFID device performs the functions formerly performed by an optical bar-code scanner, which may or may not continue to
25 be used with the device. Thus, libraries may continue to use their existing LAV software system interfaces and terminals while enjoying the added functionality and features provided by RFID technology. The RFID device need not include a display if it would cooperate with an existing LAV software system display to provide feedback to the operator. Optionally, a display and other feedback mechanisms may be included in
30 the RFID device as an integrated package.

 In devices having both RF and optical bar code reading capabilities, the device should be able to handle library materials tagged with RF tags, bar code labels, or both.

In operation, the device would process an item for check-in by scanning for an RFID tag, a barcode, or both, retrieving the item identification code and, preferably, the media type from one or both of these tags, and passing this information on to the LAV software system. When the device includes both an RFID system and an optical bar code scanning system, the device may also be used to create RFID tags for media that is only bar-coded. First, the bar code would be scanned, and then the identifier (or an ID code associated with that identifier, depending on system design) would be written to (recorded onto) the RFID tag along with other data, such as media type and other selected information returned from the LAV software system relative to that media. The RFID tag could then be applied to the item.

The RFID device of the present invention preferably also performs "smart" resensitizing and desensitizing of the magnetic security elements attached to library materials. When the device reads the RFID tag and transmits the identification information to the LAV software, the LAV software can be programmed to respond with an indication of the type of library material with which the RFID tag is associated. If the LAV software responds with an indication that the tagged material is something for which a specialized magnetization operation is required (magnetically-recorded media, typically), then the device can activate only the system that performs that operation. For example, if the LAV software indicates that the RFID tag is associated with an ordinary book, and that the book may be checked out by the requesting patron, then one magnetization system may be activated to deactivate the magnetic element associated with that book. However, if the LAV software indicates that an RFID tag is associated with a video tape, for example, then a different magnetization system may be activated to deactivate the magnetic security element associated with that video tape. This different magnetization system might involve, for example, a weaker magnetic field or a field confined to the region in the immediate vicinity of the security element, so as to prevent damage to the magnetic media itself, depending on the detailed characteristics of the security tags in use. Depending on the detailed design of the device, the procedure might include inhibiting automatic activation so as not to damage magnetic media.

Preferably, sufficient information may be stored in the memory of the RFID tag itself that the interrogation source need not transmit that information to the LAV software, and can instead invoke the appropriate magnetization system directly. This embodiment would likely improve system performance, because fewer steps are required to reach the same result. As a minimum, the RFID tag should store a media type in the memory of the RFID element, but could as noted above include additional information. This type of processing, without transmission back to a database separate from the RFID device, is referred to herein as happening in "real time."

An advantage of an RFID device such as that described is that it may accept and process items with less dependence on their orientation relative to the device. Thus, although a library material may be processed by an optical bar code scanner only when the bar code label is properly positioned and readable by the scanner, a book having an RFID tag or combination tag may be positioned with front cover either up or down, and without the need to carefully aligning a label with a scanner. This advantage of RFID systems over conventional optical and bar code systems results in considerable time savings for patrons and library staff. The "read range" may be different with different scanners, tags, and other components, but it is believed that a read range of approximately 15 centimeters (6 inches) would be satisfactory. To facilitate reliable RFID scanning, however, it may be desirable to position the RFID tags for various items at the same fixed position relative to an edge of the item. For example, RFID tags provided on library books might all be positioned 2 inches above the bottom of the book.

The benefits of the inventive RFID device are numerous and significant, and include having only a single station at which to identify, resensitize, and desensitize library materials, the elimination of operator training on and performance of different magnetization operations, increased processing speed due to the reduction of orientation constraints present in bar-code only systems, and decreased likelihood of repetitive stress injury to operators. Another benefit is that it is faster to scan RFID tags than to read a bar code, especially for codes that are inside the cover or case of the item, in large part because the user need not locate and align a bar code. Lastly, the system also is a low cost one because RFID readers are expected to cost less than high-performance

bar-code scanners. These and other benefits and advantages will be apparent to one of skill in the art.

B. Use of RFID Device with Multiple Items.

5 Another benefit of an RFID device is the ability to process multiple items at one time, as shown in Figure 10. Whereas conventional devices having only optical bar code scanners can process only a single item presented to the bar code scanner at one time, a group of items having RFID elements may be processed essentially simultaneously. This may be achieved by having multiple RFID interrogation sources (readers) mounted in or
10 on the device, or by having a single high-speed RFID reader that possesses the multi-item identification algorithms. This capability greatly reduces the time required for library staff to process multiple items.

To avoid having the device perform a magnetization operation that is
15 inappropriate for one or more of a group of materials being processed, the device may be adapted to provide a message to the user requesting that all materials of a certain kind (books and magazines, for example) be presented together, followed by all materials of another kind (video and audio tapes, for example). The RFID reader can determine from the information obtained from individual RFID elements whether the
20 user has segregated the materials appropriately, and can prompt the user if he or she has not, as shown in Figure 12. In another embodiment, the device includes one area for processing media of one type (books and magazines, for example), and a separate area for processing media of another type (video and audio tapes, for example). The proper magnetization operation may then be reliably performed as to each material.

25 The device may also include a display for indicating how many items bearing RFID tags have been presented for processing by the device. That is, the RFID reader would obtain information from each item presented to the device, and update the display to indicate that there were, for example, five items present. An optical or other detector
30 could also be used to verify that the same number of items were indeed present, so as to alert the patron or library staff if an item without an RFID tag had been inadvertently or intentionally included in the stack of other materials. Optical detectors of this type may include those described in U.S. Patent Application Serial Number 09/058,585 (Belka et

al.), filed April 10, 1998 and entitled "Apparatus and Method for the Optical Detection of Multiple Items on a Platform," which is assigned to the assignee of the present invention, the contents of which is incorporated by reference herein. Other detectors may include ones based on weight (in which the RFID reader can determine from the RFID tag or the LAV software the weight of the items detected, and compare it to the actual weight of the materials presented), or the number of magnetic elements detected (as described in U.S. Patent No. 5,260,690 (Mann et al.), the contents of which is incorporated by reference herein). Comparison of the number of items detected by the RFID reader and the number detected by an optical or other detector insures that the magnetic security elements associated with non-RFID tagged items are not deactivated without the item also being charged out to a specific patron. The device may process the items after a predetermined number of items have been presented (five items, for example), or after an operator instructs the device to process the items, or automatically without any operator intervention. A suitable display may advise the operator as to the status of the operation.

Another embodiment of the inventive device is the ability to verify the content of a package or case having multiple items inside, as shown in Figure 11. For example, a set of audio tapes may be packaged together inside a single case. To insure that only those tapes, and all of those tapes, are being processed together, the RFID reader can identify the case, and identify each of the tapes inside the case, and match the identities before permitting the materials to be checked out to a patron. The RFID tag on the case may include the information as to the contents of the case, or that information may be stored in the LAV software and accessed through the identification information obtained from the RFID tag.

Devices having the ability to process multiple materials further increases the speed with which materials may be checked into and out of a library. The device may be adapted to transmit only a single signal to the LAV software system to process multiple items, and to receive only a single signal back from that software in response.

C. Portable RFID Devices.

For a number of applications, it is desirable to provide a portable, preferably hand-held, RFID device. The hand-held RFID device is capable of searching among shelves, bins, piles and library carts. It can essentially search wherever it can be positioned close enough to the items. It is capable of identifying multiple items that are within the range of the device. These and other features make the inventive portable RFID device a valuable library tool. For simplicity, portable RFID devices will be described first in terms of their components and operation, and second in terms of various useful functions for or methods of using such devices. It is important to note that the functions or methods described herein are equally applicable to non-portable RFID devices, and that the functions or methods described above in reference to non-portable RFID devices are similarly applicable to portable RFID devices. The different functions and methods have merely been grouped together with the type of RFID device more often used to perform that function or method.

1. Components and Operation.

The hand-held RFID device of the present invention preferably includes an RFID reader and writer, memory, a power source, and software to enable various functions of the types described herein. The RFID reader/writer could consist of a Commander 320 13.56 MHz RFID reader, manufactured by Texas Instruments of Dallas, Texas. Memory, preferably in the form of a computer, may be provided by, for example, a "palm-top" or handheld computer available from 3Com Company of Santa Clara, California under the designation Palm Pilot. The portable computer may include an operating system, a touch-screen display, several buttons for developing user interfaces, a recharge station, a docking station to transfer data between the device and another computer, one or more ports to connect peripherals to the hand-held device (such as an RFID reader) and a battery power supply. Some units may also include a built-in peripheral such as a bar-code scanner. It may also contain various feedback systems, including lights, audio and a display.

As described above, there are a number of options for transferring data between the hand-held device and another processing station. A docking station approach can be used to upload or download data, as shown in Figure 14. This method could be used, for example, to upload item identification information prior to performing a search to

find those specific items. Another example would be to download data following a collection of items that have been used within the library. The link could be implemented as a docking station (as illustrated); as a wireless or cabled download and/or upload; as a wireless or cabled, real-time link between the hand-held device and another processor, or in any other manner suitable for transferring such data. One such example is a Spectrum24 wireless LAN system, from Symbol Technologies of Holtsville, New York. Systems like the Spectrum24 allow mobile users to wirelessly communicate between mobile devices and local area networks. For this operation, the mobile unit will typically include a communication component to support wireless communication, such as Symbol's LA 2400 Wireless LAN PC Card.

The user interface for the device is designed both to communicate the status of searching and to allow the user to enter data. Entering data may include switching the device among various search modes and entering data specific to a task (for example, to check out an item, or to put an item on hold). Feedback to the user is preferably provided through a combination of sound, lights and a display. The display may either be integrated into the unit or separated. When separate, it can be designed in various ways, including as a "wearable" display that can be easily viewed by the user.

A particularly useful embodiment of the hand-held RFID device is as follows. A hand-held RFID device is provided in which the RFID reader, user interface, power source, antenna, processor, and software are all provided in a single integrated unit, as shown in Figure 13. By using a hand-held computer such as the Palm Pilot described above, a number of real-time functions of the type described below can be achieved, in contrast to systems in which the RFID device must interact with a separate computer, database, software system, and the like. The software can also provide either limited or full-range capabilities for supporting functions of the type described herein, as desired. The hand-held RFID device also preferably includes an integral power source, although it can be tethered to a larger power source of the type that might be worn around a user's waist. In the case of an integral power source, the source may or may not power the processor, and may be recharged when connected to a docking station. When a hand-held computer is used, it may include its own power source, and may be recharged

when connected to the docking station to upload and/or download information, as shown in Figure 14.

5 A hand-held RFID device can interrogate and identify RFID-tagged items whenever it is activated within range of the items. Intermittent activation can be provided by, for example, a trigger associated with the device, so that the elapsed time for which power is required for the RFID device is minimized. The reading distance is a function of many factors, but is expected to be between 15 and 45 centimeters (6 and 18 inches) given current technology and the likely frequencies at which the system would
10 operate. In some applications, it may be desirable to restrict the operating range of the device so that it only interrogates RFID tags associated with items at a closer range. In other cases, the longest available range of operation will be desired. In other applications, it may be preferred to restrict the output power (and thus the reading range) to permit longer continuous operation from the battery pack. The read range will
15 also be influenced by the design of the antenna as well as the orientation of the RFID tag relative to the antenna. It should be appreciated that the read range, battery weight, and lifetime between battery recharges or replacement are often dependent on each other. Various tradeoffs can be envisioned, based on the particular application for the device.

20 In operation, a particularly useful feature of a hand-held device is obtaining real-time information regarding an item that has been scanned by the device. That is, the hand-held device obtains information from the RFID tag, and either immediately displays that information, or immediately displays information stored within the hand-held device that is related to the tagged item. This is in contrast to devices that must be docked with
25 or otherwise communicate with a separate database of information before that information can be displayed for the user. The hand-held device of the present invention can also be docked or can otherwise communicate with a separate database, if such features are desired.

30 2. Functions, Methods, and Applications. The hand-held RFID device of the present invention can be used for a number of functions, methods, and applications, including the following.

The inventive handheld RFID device has particular usefulness in item location. For example, the device could be programmed with specific information identifying certain items that an operator wishes to locate. The unique identifier for each desired item would be stored in a reserved memory location in the handheld computer. As the
5 identifiers of, for example, items on a shelf were read by the RF reader, each would be compared, using standard software routines known to those skilled in the art, with the list of items stored in memory. When a match occurred, the device would then create one or more visual, audio, tactile, or other signals indicating the presence of the item. One application for this function includes locating items that are believed to be missing.
10 A library typically maintains a list of missing items – those items that are expected to be in the library, but cannot be found. By downloading those missing item identifiers to the hand-held device, the operator can pass the device by items and obtain feedback when a missing item is encountered.

15 Another example is to locate items that have not circulated or been used within a given number of months. Again, the identifiers of those items could be downloaded to the hand-held device for searching. Alternatively, the circulation counts can be maintained directly on the memory of the RFID tag. In this case, the hand-held device does not need to download any data from another computer system. The hand-held
20 device only compares RFID memory data to established criteria and provides feedback to the operator based on the selected parameters.

Another example of where data can be either downloaded from a library data base to the hand-held or obtained directly from the RFID tag is to locate items in the
25 library that have not been checked in. A list of items not checked-in could be obtained and then downloaded to the hand-held device or the RFID tag could maintain a memory location to indicate the check-in status of an item. When the RFID tag memory indicates the check-in status, the hand-held device does not need any data from an external database to perform the search. A natural application of obtaining matching
30 data directly from the RFID tag is to locate items that belong to different library buildings or to different library systems. For this application, the owning library is preferably encoded onto the RFID tag and the hand-held device alerts the operator when an RFID tag with a different owning library code is encountered. The hand-held RFID

device could also be used to determine, as with the RFID device described above, whether all members of a set of associated items are present together, as with the tapes in a books-on-tape case.

5 The RFID device of the present invention could also be used to verify the order of materials on a shelf. In this mode, the device is scanned across one or more rows of items. The device reads each item and indicates, to the operator, which items are not shelved in the correct order. As input, the device has access to the shelving algorithm used by the library for the section being scanned. Possible algorithms include: Dewey
10 Decimal order, Library of Congress order, and Author last name/Title order. Other methods of sorting, as determined by each library, are possible.

 Another method of establishing shelf information is to associate each item with a location. Shelf locations can be as specific or as general as the library desires. For
15 example, a general shelf location might include all "Adult Fiction titles." A more specific shelf location might be "Adult Fiction, Authors AA – AB." In the preferred embodiment, the shelf location for an item is encoded directly in the RFID tag memory for that item. An indexing system may also be used to save memory, so that a short code number is used to indicate a shelf location. For example, the number 1 could
20 represent Adult Fiction, the number 2 could represent Juvenile Fiction, and so on. The amount of memory needed to store all shelf locations depends on the number of locations within a library. Another embodiment is to obtain the desired shelf location from a library database and then download those locations as part of the transfer of data to the hand-held device.

25 When items are associated with a shelf location, by either method above, the operator can use the hand-held device to locate items that are in the wrong location. Two processing methods can be used to determine which shelf location is currently being processed in order to search for items with non-matching locations. In one
30 embodiment, the correct shelf location is obtained by reading several RFID tags and heuristically processing the data to infer a location. For example, if the RFID device reads a certain number of tags that are indexed to the Adult fiction area, the device can be programmed to alert the user when non-Adult Fiction items are encountered. In

another embodiment, the library places "location tags" on the shelves or other locations to be searched. These location tags are first read by the hand-held device to indicate that subsequent items read should belong to that location and an alert is provided when a mismatch occurs.

5

In another embodiment, the hand-held RFID device may be used to enter data into the device as to a specific item. That information may be either transmitted immediately and directly to the LAV software, or may be transmitted subsequently when the hand-held device is reconnected to a docking station and downloads the information to the LAV software. For example, when a user takes a library material from its location, the user may input the new status of the article into the hand-held RFID device. Because this information must be entered into the LAV software eventually, it saves the operator time to be able to indicate this state directly and immediately as opposed to waiting until he or she can access an LAV software system terminal.

10
15

In yet another embodiment, the hand-held device could be used to provide additional information about a specific item once the item has been obtained and its RFID tag scanned by the RFID device. For example, library staff may collect materials that have been used in the library, and scan those materials either to obtain more information about that material (who last checked it out; how often has it been used) or to provide information to a database that generates statistical profiles of library material usage, or both. The operator simply reads the RFID tags of the items as they are collected from the various locations in the library at which they were used. As items are collected, the operator can also indicate from where the items was collected by selecting from a list of locations, entering a location code or reading a "location RFID Tag" that is associated with that location and would preferably be affixed to or near that location. In this way, the library staff is able to obtain additional information about where in the library such materials were used. Alternatively, if items used in the library are first placed on a book cart, for example, the hand-held device could make a single pass by the items on the cart to record them. The functions described in this paragraph are referred to herein as "sweeping."

20
25
30

The benefits of a hand-held RFID device are numerous, and include the ability to locate items more quickly and accurately compared to reading each call number or title from items, the ability to “get close” to desired item quickly and then examine items more closely to locate item of interest, the ability to quickly identify items matching a given set of criteria (lost, not checked out, matching specific circulation values, etc.), and the ability to identify items that are mis-shelved and indicate, to the operator, the correct location for the items. This would include items that don’t belong in the collection being scanned. Other advantages include the ability to enter transactions directly into the hand-held unit when items are located, the ability to identify an item without having to scan a bar code or any other markings on the item, such as author, title and call number, and the ability to determine if a given item is somewhere on a shelf, on a library cart, in a bin, on a table or even in a pile. These and other advantages will be apparent to those of skill in the art.

In the claims appended hereto, persons of ordinary skill will recognize that the items recited could be library materials (including books, periodicals, magnetic or optical media, and the like), or could be other completed unrelated materials such as packages, letters, paintings, electronic devices, animals, automobiles, bicycles, or any other items of value.

20

We claim:

1. An RFID device for processing items having an RFID element and a magnetic security element associated therewith, comprising:
 - (a) an RFID interrogation source for interrogating and obtaining
5 information from the RFID element; and
 - (b) a magnetization system for performing an appropriate magnetization operation on the magnetic security element in response to the information obtained from the RFID element.
- 10 2. The RFID device of claim 1, wherein the device determines the appropriate magnetization operation directly in response to information obtained from and contained within the RFID element itself.
- 15 3. The RFID device of claim 1, wherein the device determines the appropriate magnetization operation after the information obtained from the RFID element has been compared to information in a database separate from the RFID element.
- 20 4. The RFID device of claim 1, wherein the device is adapted to provide an indication that an item is a specific type of item.
- 25 5. The RFID device of claim 2, wherein the device is adapted to perform no magnetization operation in response to the information obtained from the RFID element.
6. The RFID device of claim 1, wherein the device further comprises an optical bar code scanner.
- 30 7. The RFID device of claim 6, in which information obtained by the optical bar code scanner may be written to an RFID tag to be associated with the item.
8. The RFID device of claim 1, wherein the device further comprises a computer.

9. The RFID device of claim 8, wherein the computer is adapted to operate library automation vendor software for managing the flow of materials into and out of a library.

5

10. The RFID device of claim 1, wherein the RFID interrogation source interrogates and obtains information about the RFID element regardless of the orientation of the RFID element relative to the interrogation source.

10

11. A method of performing a magnetization operation on a magnetic security element associated with an item, comprising the steps of:

(a) interrogating an RFID element associated with that item to obtain information;

15

(b) using the information to determine the type of item with which the RFID element is associated; and

(c) performing an appropriate magnetization operation on the magnetic security element based on the type of material with which it is associated.

20

12. The method of claim 11, wherein the item comprises magnetically-recorded media, and the magnetization operation is the application of a magnetic field to the magnetic security element that is sufficient to activate or deactivate the element without damage to the magnetically-recorded media.

25

13. The method of claim 11, wherein the appropriate magnetization operation is the absence of magnetization.

30

14. A method of processing a set of associated items each having an RFID element, comprising the steps of:

(a) interrogating each of the items to obtain information including the identity of the item;

(b) interrogating an RFID element that is associated with the set of associated items;

(c) comparing the information obtained in step (a) with the information obtained in step (b) to determine whether the associated items are presented together.

5 15. The method of claim 14, wherein the method further includes the step of:

(d) determining whether other items are included with the associated items that are not members of the set of associated items.

10 16. The method of claim 14, wherein the method further includes the step of:

(d) determining whether any of the associated items are missing from the set.

15 17. The method of claim 14, wherein the method further includes the step of:

(d) performing a magnetization operation on magnetic security elements associated with the items.

20 18. A method of processing multiple items each having an RFID element, comprising the steps of:

(a) presenting more than one of said items to an RFID reader;

(b) obtaining information from the RFID elements approximately simultaneously; and

25 (c) using the information obtained from the RFID elements to determine whether different types of items are among the items presented.

19. The method of claim 18, wherein the method further includes the step of:

30 (d) providing an indication to a user that different types of items are among the items presented.

20. A method of processing multiple items having an RFID element, comprising the steps of:

- (a) presenting more than one of the items to an RFID reader;
- (b) obtaining information from the RFID elements approximately simultaneously;
- (c) detecting the number of RFID elements presented;
- 5 (d) automatically processing the items when only a predetermined number of items have been detected.

10 21. The method of claim 20, wherein the processing step comprises performing an appropriate magnetization operation on magnetic security elements associated with the items presented to the RFID reader.

15 22. The method of claim 20, wherein the processing step comprises updating a database that includes information as to the items presented to the RFID reader.

20 23. A method of processing multiple items having an RFID element, comprising the steps of:

- (a) presenting more than one of the items to an RFID reader;
- (b) obtaining information from the RFID elements approximately simultaneously;
- (c) detecting the number of RFID elements presented;
- (d) displaying the number of RFID elements detected to a user; and
- (e) permitting the user to direct that the items be processed.

25 24. The method of claim 23, wherein the processing step comprises performing an appropriate magnetization operation on magnetic security elements associated with the items presented to the RFID reader.

30 25. The method of claim 23, wherein the processing step comprises updating a database that includes information as to the items presented to the RFID reader.

26. A hand-held RFID device, comprising as an integrated unit:

- (a) a computer;
- (b) an antenna to transmit commands between an RFID tag and an RFID reader;
- (c) an RFID reader for reading information from multiple RFID elements substantially simultaneously; and
- (d) a display.

5

27. The hand-held RFID device of claim 26, further comprising:

- (d) an RFID writer for transmitting information to an RFID element for storage therein.

10

28. The hand-held RFID device of claim 26, further comprising:

- (d) a data transfer system for transferring data from the RFID device to a separate database.

15

29. The hand-held RFID device of claim 28, wherein the data transfer system comprises a connection for operatively coupling with a docking station.

30. The hand-held RFID device of claim 28, wherein the data transfer system comprises a cabled data transfer connection.

20

31. The hand-held RFID device of claim 28, wherein the data transfer system comprises a wireless data transfer system.

25

32. The hand-held RFID device of claim 26, wherein the device includes an integral power source.

33. The hand-held RFID device of claim 26, wherein the computer is a detachable hand-held computer.

30

34. The hand-held RFID device of claim 33, wherein the computer includes a power source separate from the source of power for the remainder of the device.

35. The hand-held RFID device of claim 33, wherein the detachable hand-held computer comprises a connection for operatively coupling with a docking station.

5

36. The hand-held RFID device of claim 26, further comprising:

(d) an information input system for providing information to the RFID device other than by radio frequency interrogation.

10

37. A method of using a portable RFID device, comprising the steps of:

(a) inputting information to the device describing a certain item or class of items each having an RFID element; and

(b) scanning a plurality of items to determine whether the certain item or items are present.

15

38. The method of claim 37, wherein the information is selected from information describing missing items, items that have not been used within a specified period of time, items that have not been checked into inventory, items that have been designated for hold status, and the owner of the items.

20

39. The method of claim 37, wherein the information is contained within and available from the RFID element itself.

25

40. The method of claim 37, wherein the method further includes the step of:

(c) providing an indication in real time to a user that the item or items of interest were located.

30

41. The method of claim 40, wherein the method further includes the step of:

(d) recording in a database that the item or items of interest were located.

42. A method of using a portable RFID device, comprising the steps of:
- (a) inputting an algorithm to the device that describes an ordered set of items;
 - (b) scanning a plurality of items having RFID elements to obtain information from those elements; and
 - (c) comparing a description of the items obtained using the information obtained from the RFID elements to the algorithm to determine whether the scanned items are in the algorithm order.
43. The method of claim 42, wherein the method further comprises the step of:
- (d) providing an indication to a user of any item that is not in the algorithm order.
44. The method of claim 43, wherein the indication is provided in real time.
45. The method of claim 43, wherein the indication is provided in response to information obtained from a database separate from the RFID device and the RFID tag.
46. The method of claim 42, wherein the algorithm is based on an ordering system that is selected from the Dewey Decimal System, the Library of Congress System, an alphabetical listing of authors, and an alphabetical listing of topics.
47. A method of using a portable RFID device to associate an item bearing an RFID element with a location, comprising the steps of:
- (a) scanning the RFID element associated with the item;
 - (b) inputting information to the device to describe the location; and
 - (c) associating the item with the location in a database.

48. The method of claim 47, wherein the location has a separate RFID element, and step (b) comprises scanning the RFID element associated with that location.

5 49. A method of using a portable RFID device to associate a certain item bearing an RFID element with a location having a group of items of a similar type each also bearing an RFID element, comprising the steps of:

 (a) scanning the RFID element associated with the item;

 (b) scanning the RFID elements of at least one additional item within the

10 group of items;

 (c) determining whether the certain item belongs with the group of items.

 50. The method of claim 49, wherein the method further comprises the

15 step of:

 (d) providing an indication of the determination made in step (c) to the user in real time.

 51. A method of using a portable RFID device, comprising the steps of:

20 (a) obtaining an item having an RFID element associated therewith;

 (b) using the portable RFID device to interrogate the RFID element and obtain information therefrom; and

 (c) inputting information to the RFID device as to that item by other than RFID interrogation.

25 52. The method of claim 51, wherein the method further includes the step of:

 (d) using the information input in step (c) to update a database that includes information as to that item.

30 53. The method of claim 52, wherein the database is updated when the portable RFID device is connected to a docking station to download information to that database.

54. A method of using a portable RFID device with an item having an RFID element associated therewith, comprising the steps of:

- 5 information therefrom;
- (a) interrogating the RFID element with the RFID device to obtain
 - (b) identifying the item using the information obtained; and
 - (c) requesting from the portable RFID device further information regarding the item.

10 55. The method of claim 54, wherein the information requested in step (c) is obtained from memory contained within the portable RFID device.

15 56. The method of claim 54, wherein the information requested in step (c) is obtained from memory that is separate from the portable RFID device and is transferred to the device.

57. A method of using an RFID device, comprising the steps of:

- 20 (a) interrogating a group of items each bearing an RFID tag;
- (b) providing to the RFID device information identifying a certain class of items; and
 - (c) receiving in real time from the RFID device an indication of items that are not within the certain class of items.

25 58. The method of claim 57, wherein the class of items are items associated with a particular location, and the information provided in step (b) includes that location.

59. A method of using an RFID device with items of interest that bear an RFID tag, comprising the steps of:

- 30 (a) interrogating the tagged items with the RFID device; and
- (b) entering information into the RFID device describing the location of the item of interest.

60. The method of claim 59, further comprising the step of:

(c) collecting in a database the information entered in step (b) regarding the items of interest.

5 61. The method of claim 60, wherein the database is contained within the RFID device.

 62. The method of claim 60, wherein the database is separate from the RFID device, and the information is transferred to that database.

10

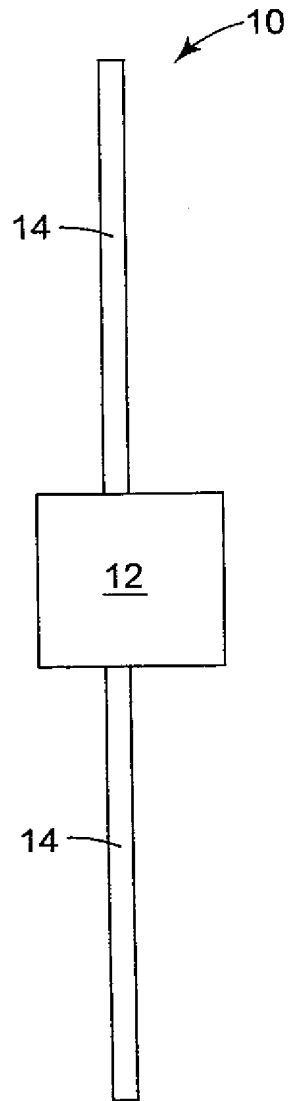

Fig. 1A

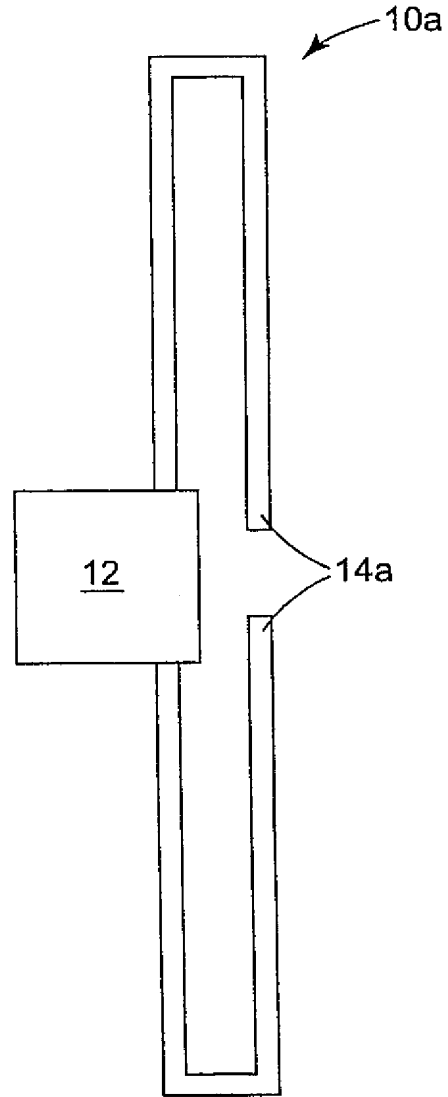

Fig. 1B

2/10

10b

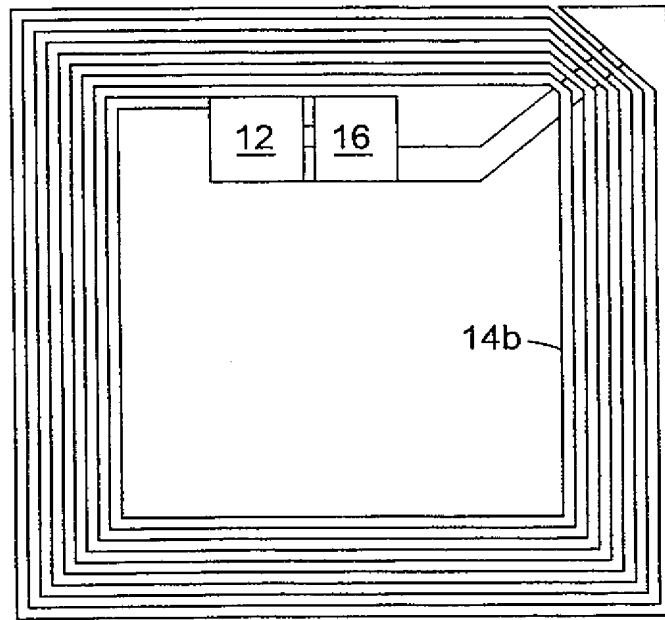

Fig. 2

20d

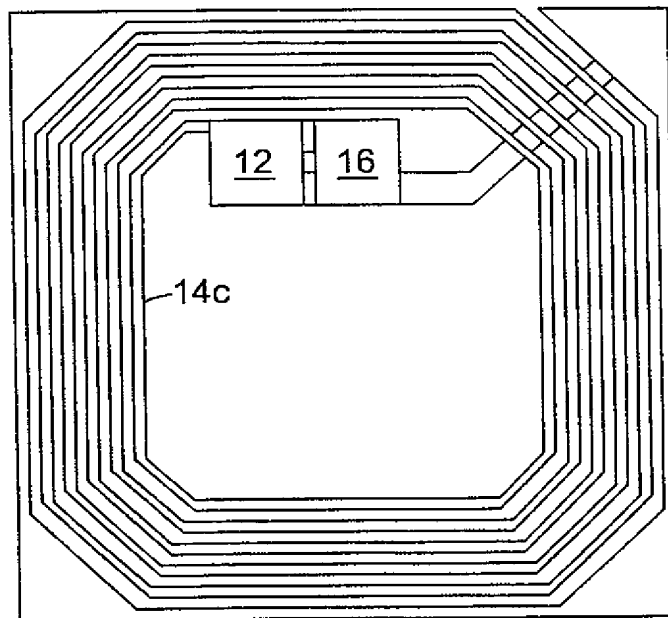

Fig. 3

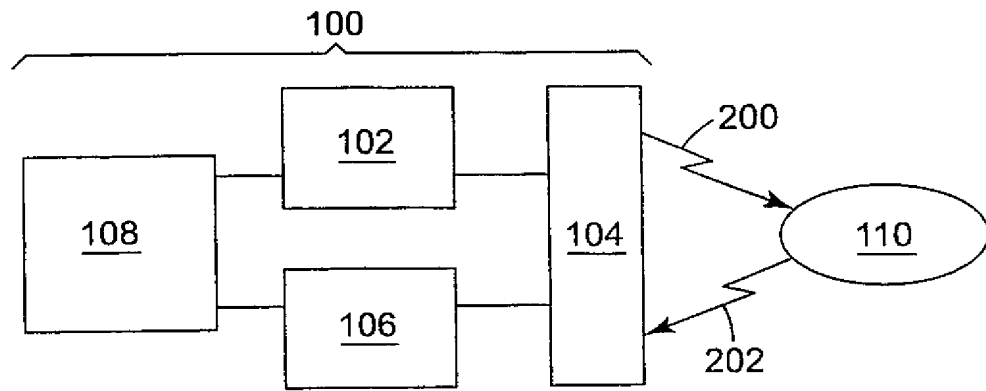

Fig. 4

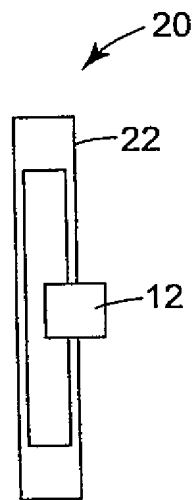

Fig. 5

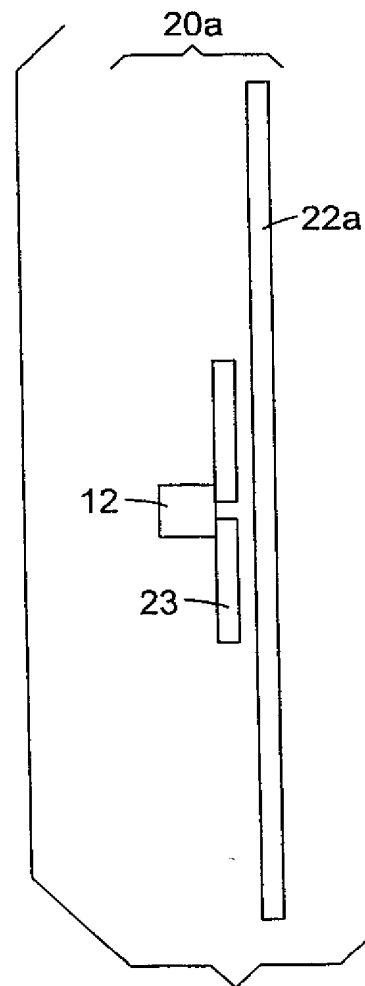

Fig. 6

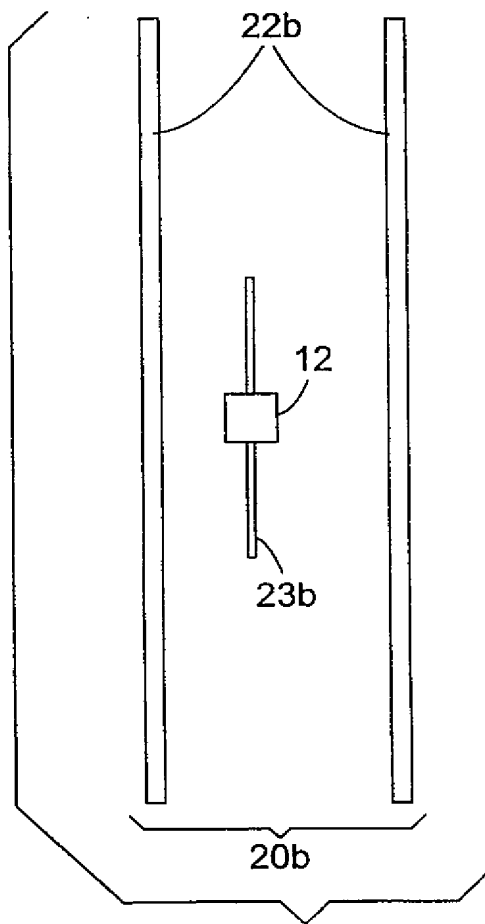

Fig. 7

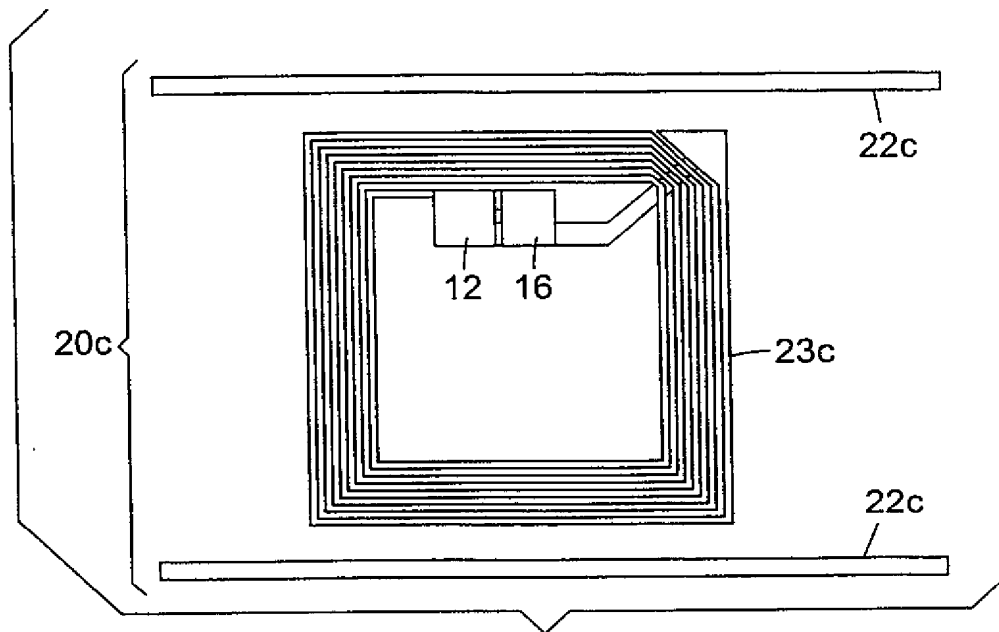

Fig. 8

5/10

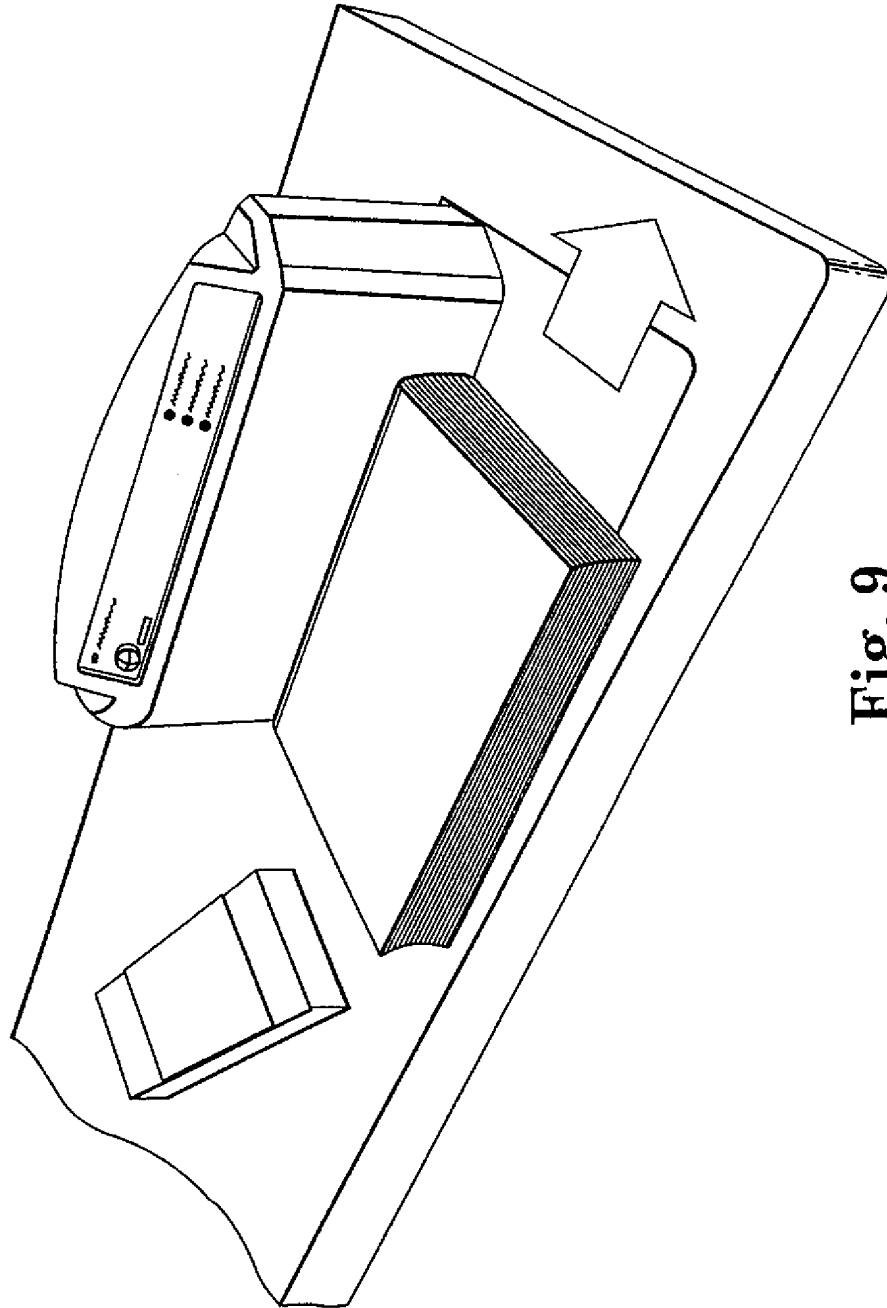

Fig. 9

6/10

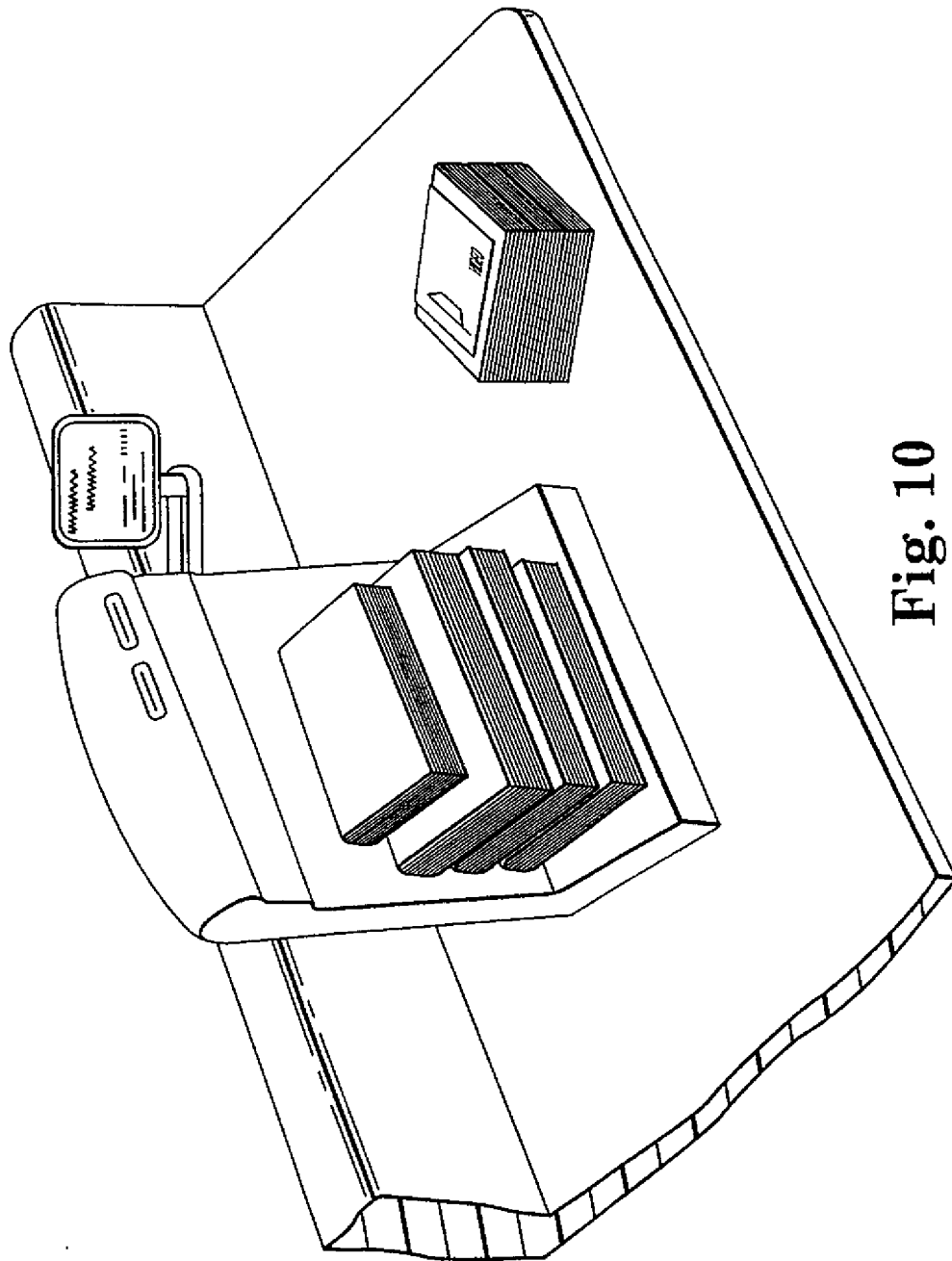

Fig. 10

7/10

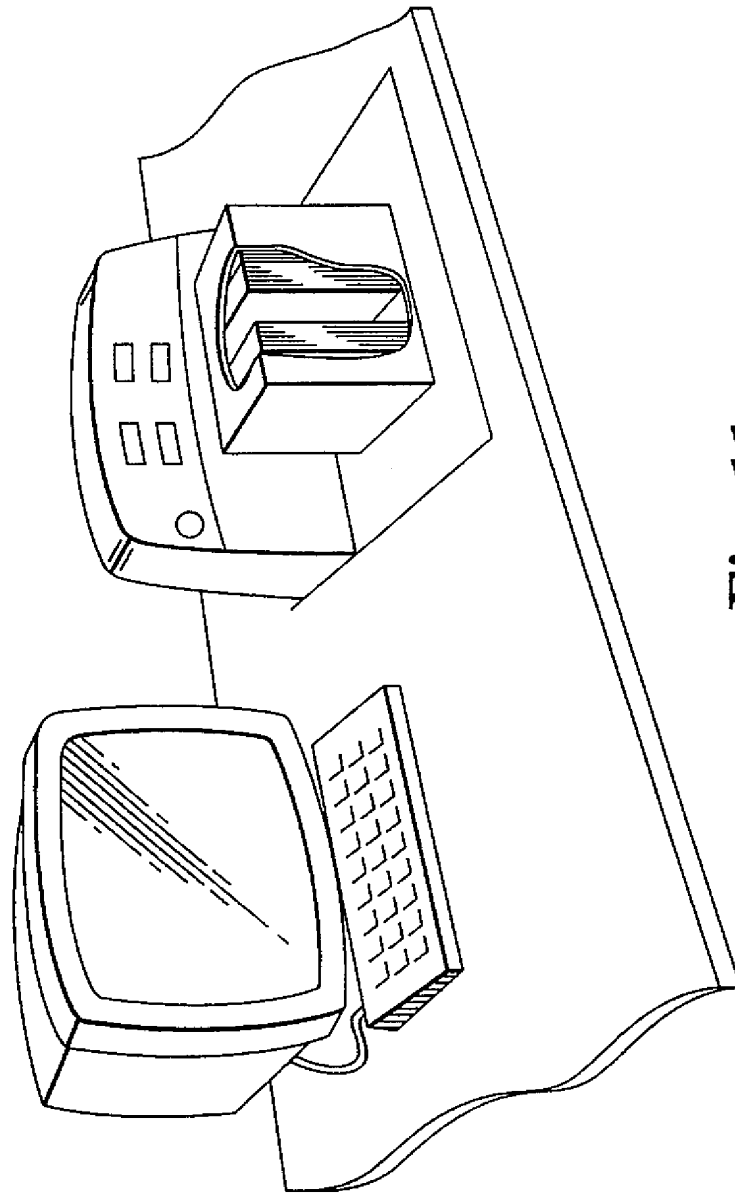

Fig. 11

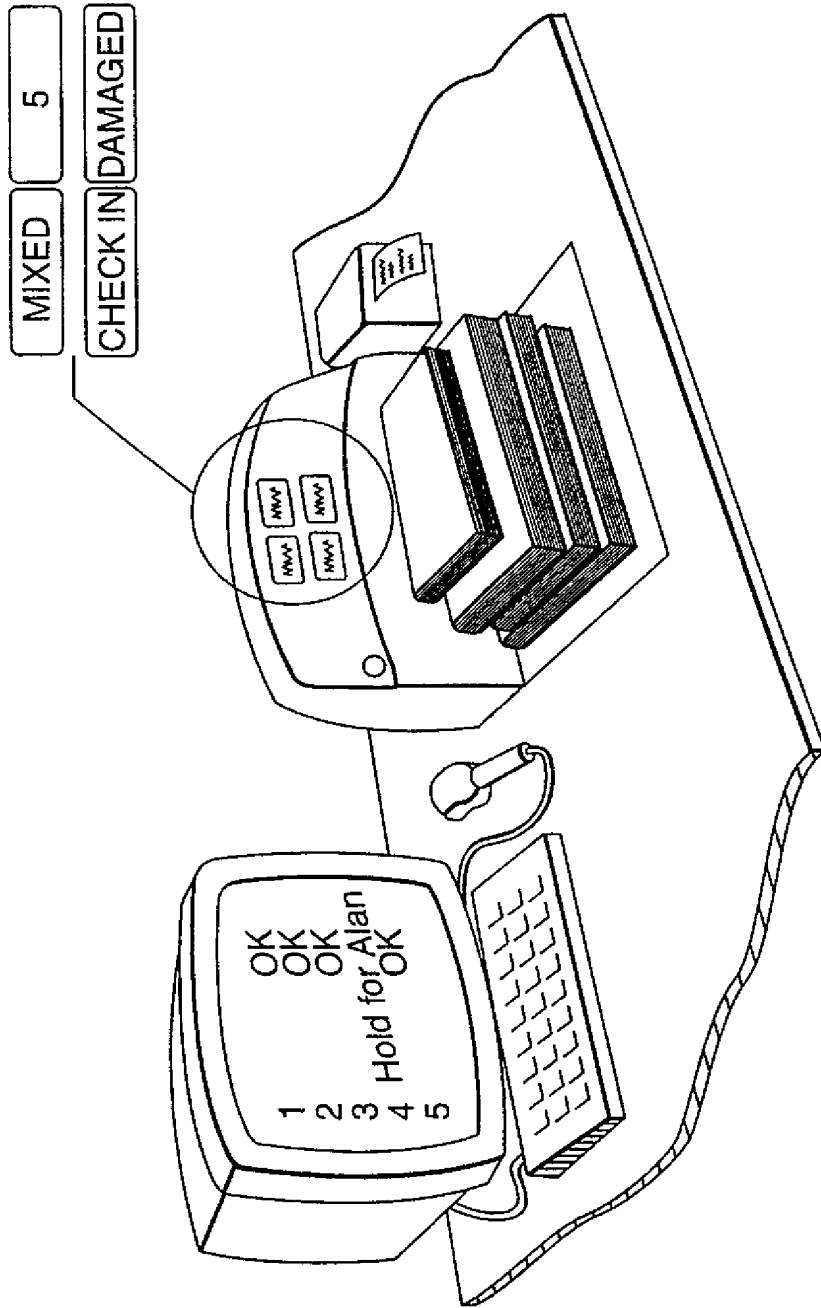

Fig. 12

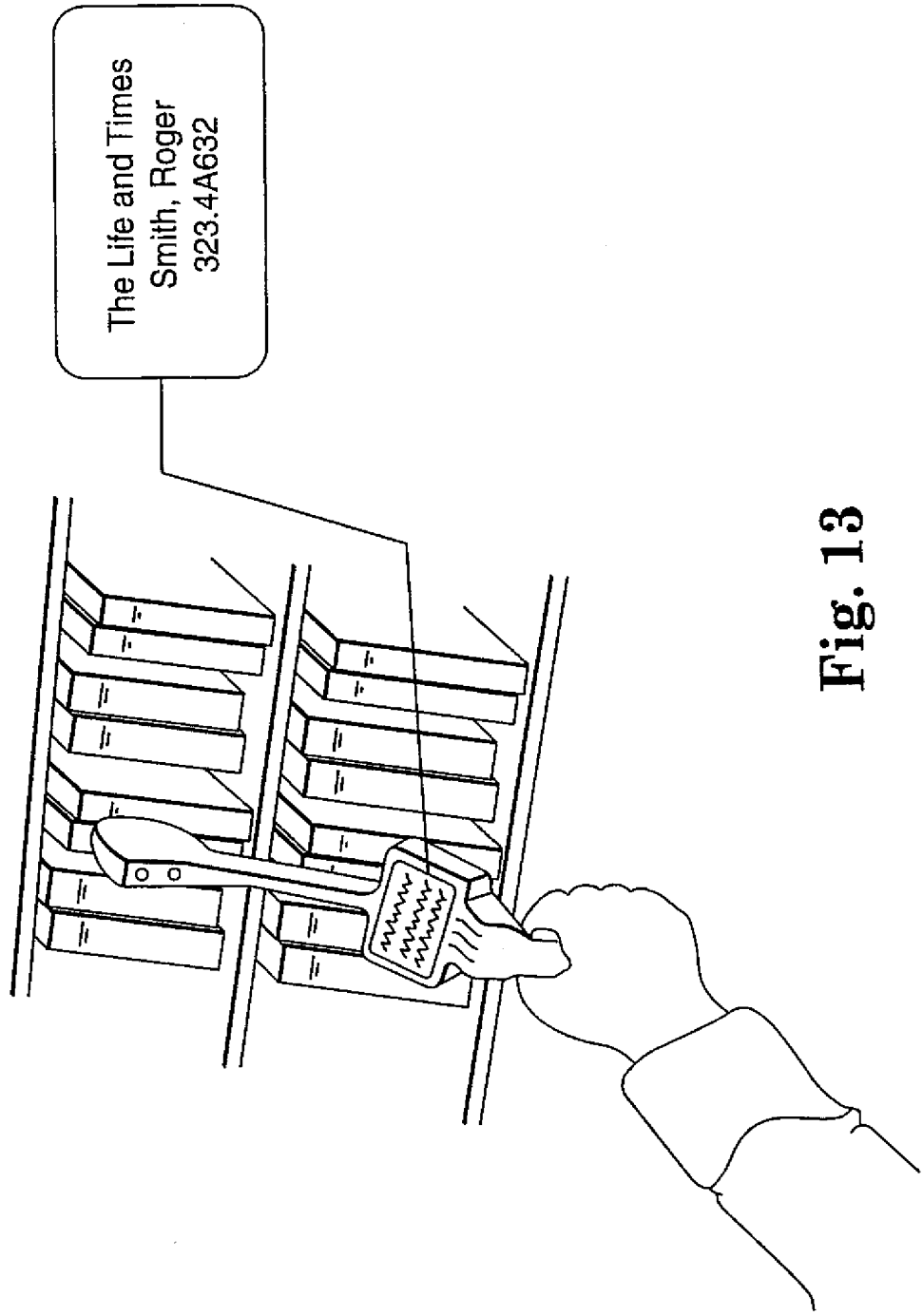

Fig. 13

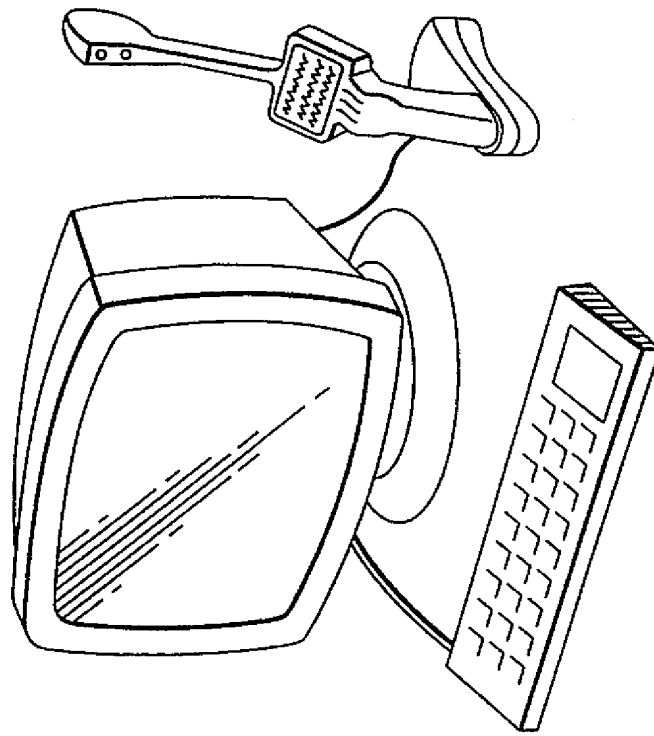

Fig. 14

INTERNATIONAL SEARCH REPORT

Int. Application No
PCT/US 99/17767

A. CLASSIFICATION OF SUBJECT MATTER
IPC 7 G08B13/24 G07F7/00 G06F17/60

According to International Patent Classification (IPC) or to both national classification and IPC

B. FIELDS SEARCHED

Minimum documentation searched (classification system followed by classification symbols)
IPC 7 G08B G07F G06F

Documentation searched other than minimum documentation to the extent that such documents are included in the fields searched

Electronic data base consulted during the international search (name of data base and, where practical, search terms used)

C. DOCUMENTS CONSIDERED TO BE RELEVANT

Category *	Citation of document, with indication, where appropriate, of the relevant passages	Relevant to claim No.
X	WO 98 13805 A (SENSORMATIC ELECTRONICS CORP) 2 April 1998 (1998-04-02) the whole document ---	1, 2, 5, 10
X	US 5 640 002 A (AMES RONALD MERLE ET AL) 17 June 1997 (1997-06-17) ---	1-3, 5-8, 10-13, 26-37, 39-41, 51-62
Y A	column 32, line 1 - column 38, line 52; figures 27-33 ---	9, 42-62 14, 18, 37, 47, 49
Y	EP 0 702 323 A (IBM) 20 March 1996 (1996-03-20) ---	37-46
A	page 2, column 2, line 25 - page 3, column 3, line 21 page 6, column 10, line 1 - line 29 ---	1, 4, 5, 8, 11, 13-25
	-/--	

Further documents are listed in the continuation of box C.

Patent family members are listed in annex.

* Special categories of cited documents :

- "A" document defining the general state of the art which is not considered to be of particular relevance
- "E" earlier document but published on or after the international filing date
- "L" document which may throw doubts on priority claim(s) or which is cited to establish the publication date of another citation or other special reason (as specified)
- "O" document referring to an oral disclosure, use, exhibition or other means
- "P" document published prior to the international filing date but later than the priority date claimed

- "T" later document published after the international filing date or priority date and not in conflict with the application but cited to understand the principle or theory underlying the invention
- "X" document of particular relevance; the claimed invention cannot be considered novel or cannot be considered to involve an inventive step when the document is taken alone
- "Y" document of particular relevance; the claimed invention cannot be considered to involve an inventive step when the document is combined with one or more other such documents, such combination being obvious to a person skilled in the art.
- "&" document member of the same patent family

Date of the actual completion of the international search

25 January 2000

Date of mailing of the international search report

01/02/2000

Name and mailing address of the ISA
European Patent Office, P.B. 5818 Patentlaan 2
NL - 2280 HV Rijswijk
Tel. (+31-70) 340-2040, Tx. 31 651 epo nl,
Fax: (+31-70) 340-3016

Authorized officer

Reekmans, M

INTERNATIONAL SEARCH REPORT

International Application No
PCT/US 99/17767

C.(Continuation) DOCUMENTS CONSIDERED TO BE RELEVANT

Category *	Citation of document, with indication, where appropriate, of the relevant passages	Relevant to claim No.
X	WO 98 16070 A (AMTECH CORP) 16 April 1998 (1998-04-16) claims 1-5,21,28-53	23-36, 51-53, 59-62
Y	WO 98 13800 A (ELENCO ELECTRONICS INC) 2 April 1998 (1998-04-02) page 2, line 9 -page 4, line 7	37-41, 47-62
Y	WO 97 15031 A (MINNESOTA MINING & MFG) 24 April 1997 (1997-04-24)	9
A	abstract; claims	1-4,11, 12,20-25
A	WO 90 05968 A (CHECKPOINT SYSTEMS INC) 31 May 1990 (1990-05-31) page 5, line 2 -page 8, line 9 page 15, line 34 -page 16, line 26	1,2,8,9, 11
A	US 5 151 684 A (JOHNSEN EDWARD L) 29 September 1992 (1992-09-29) column 2, line 59 -column 3, line 58; claims	1-3,6-8, 14, 26-36, 51-53, 59-62
A	US 4 141 078 A (BRIDGES JR LOUIS E ET AL) 20 February 1979 (1979-02-20) column 1, line 42 -column 3, line 39	1,3,6
E	WO 99 65006 A (MINNESOTA MINING & MFG) 16 December 1999 (1999-12-16) cited in the application the whole document	1-3,5
A	US 5 334 822 A (SANFORD MICHAEL D) 2 August 1994 (1994-08-02)	
A	WO 98 13804 A (SENSORMATIC ELECTRONICS CORP) 2 April 1998 (1998-04-02)	
A	WO 95 12870 A (KNOGO CORP) 11 May 1995 (1995-05-11)	

INTERNATIONAL SEARCH REPORT

International application No.

PCT/US 99/ 17767

Box I Observations where certain claims were found unsearchable (Continuation of item 1 of first sheet)

This International Search Report has not been established in respect of certain claims under Article 17(2)(a) for the following reasons:

1. Claims Nos.:
because they relate to subject matter not required to be searched by this Authority, namely:

2. Claims Nos.:
because they relate to parts of the International Application that do not comply with the prescribed requirements to such an extent that no meaningful International Search can be carried out, specifically:

3. Claims Nos.:
because they are dependent claims and are not drafted in accordance with the second and third sentences of Rule 6.4(a).

Box II Observations where unity of invention is lacking (Continuation of item 2 of first sheet)

This International Searching Authority found multiple inventions in this international application, as follows:

SEE ADDITIONAL SHEET

1. As all required additional search fees were timely paid by the applicant, this International Search Report covers all searchable claims.
2. As all searchable claims could be searched without effort justifying an additional fee, this Authority did not invite payment of any additional fee.
3. As only some of the required additional search fees were timely paid by the applicant, this International Search Report covers only those claims for which fees were paid, specifically claims Nos.:
4. No required additional search fees were timely paid by the applicant. Consequently, this International Search Report is restricted to the invention first mentioned in the claims; it is covered by claims Nos.:

Remark on Protest

- The additional search fees were accompanied by the applicant's protest.
- No protest accompanied the payment of additional search fees.

FURTHER INFORMATION CONTINUED FROM PCT/ISA/ 210

1. Claims: 1-13

Method and device for the magnetization of a magnetic security element in a RFID system with RFID elements and RFID reader and processing device.

2. Claims: 14-25

Method of processing a set of associated or multiple items each having a RFID element in a RFID system for processing items.

3. Claims: 26-62

Hand-held RFID device and method of using such a device with input means for searching or locating items.